

161

Soft Serve Freezer

Compact Twin Twist, Taylormate®

Features

Offer all the popular soft serve variations from low or non-fat ice creams to custard, yogurt and sorbet. Serve two separate soft serve flavors, or an equal combination of both in a twist.

Freezing Cylinder

Two, 1.5 quart (1.4 liter).

Mix Hopper

Two, 8 quart (7.6 liter). Separate hopper refrigeration (SHR) maintains mix below 41°F (5°C) in Auto and Standby modes.

Indicator Lights

Mix Low light alerts the operator to add mix.

Electronic Controls

Finished product quality is monitored by Softech™ controls that measure viscosity.

Standby

During long no-use periods, the standby feature maintains safe product temperatures in the mix hopper and freezing cylinder.

Air Filter

Easily removable, cleanable air filter helps keep condenser clean for optimal refrigeration system performance.



Photo shows Model 161 with optional cart



Standard 6

 LISTED
SA2650

 Selected 50
Hz. Models

161 Soft Serve Freezer

161

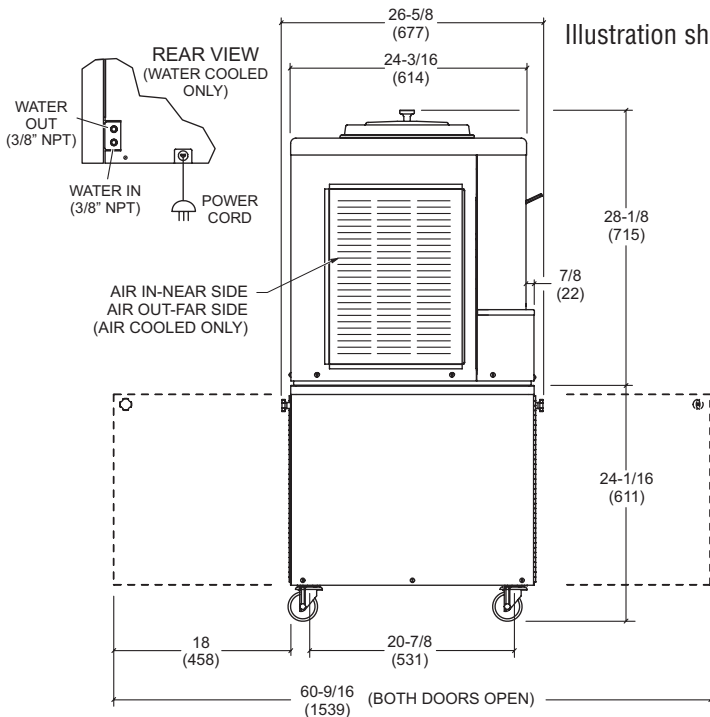
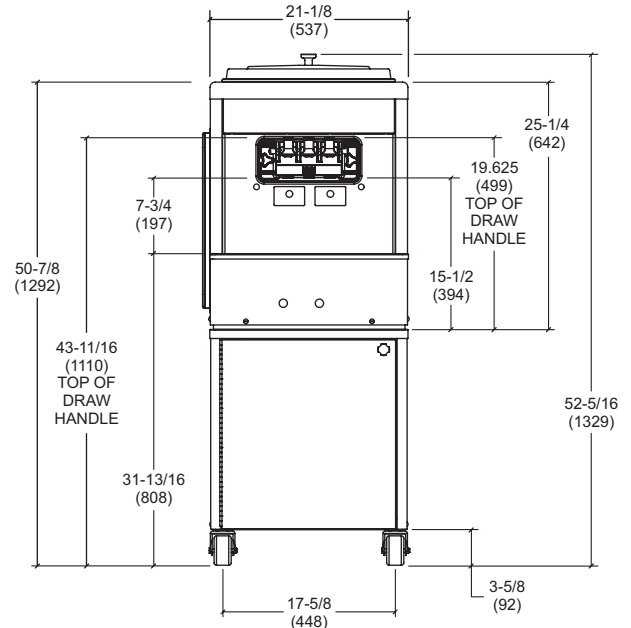

Illustration shows optional cart



NOTE:
FIGURES IN PARENTHESES INDICATE MILLIMETERS.

| Weights | lbs. | kgs. |
|---------|---------|--------|
| Net | 305 | 138.3 |
| Crated | 355 | 161.0 |
| | cu. ft. | cu. m. |
| Volume | 17.9 | 0.51 |

| Dimensions | in. | mm. |
|-------------------|--------|-----|
| Width | 21-1/8 | 537 |
| Depth | 26-5/8 | 677 |
| Height | 28-1/8 | 715 |
| Counter Clearance | ----- | |

Designed to rest on a plastic pad directly on counter top or optional cart.

| Electrical | Total Amps | Supplied with NEMA Cord |
|--------------------|------------|-------------------------|
| 208-230/60/1 Air | 10.0 | 6-15P |
| 220-230/60/1 Water | 10.0 | 6-15P |
| 220-240/50/1 Air | 15.0 | ---- |
| 220-240/50/1 Water | 15.0 | ---- |

This unit may be manufactured in other electrical characteristics. Refer to the local Taylor Distributor for availability.
(For exact electrical information, always refer to the data label of the unit.)

Bidding Specs

Electrical: Volt _____ Hz _____ ph _____
Neutral: Yes No Cooling: Air Water NA

Options: _____

Specifications

Electrical

One dedicated electrical connection is required. See the Electrical chart for the proper electrical requirements. Manufactured to be cord connected. Consult the international Taylor distributor for cord & receptacle specifications for 50 Hz. equipment.

Beater Motor

Two, 0.5 HP

Refrigeration System

One, 4,900 BTU/hr compressor (nominal rating). R404A.
Separate Hopper Refrigeration (SHR), One, 300 BTU/hr. R134a.
(Actual BTUs will vary based on application.)

Air Cooled

Minimum Clearance: 6" (152 mm) on left and right, and 0" in the rear. Install the air deflector provided, and place the rear of the unit against the wall to prevent recirculation of warm air. Minimum air clearances must be met to assure adequate air flow for optimum performance.

Water Cooled

Water inlet and drain connections out of rear 3/8" FPT.

Options

- Cone Dispenser
- Cart with casters C20400-000
Net Weight: 105 lbs. (47.6 kg)
Crated Weight: 130 lbs. (59.0 kg)
- Legs - [increase height of unit by 4-1/4" (108 mm)]

Continuing research results in steady improvements; therefore, these specifications are subject to change without notice.



Taylor Company,
A Division of Carrier Commercial Refrigeration, Inc.
Rockton, Illinois 61072
815-624-8333 **800-255-0626** Fax 815-624-8000
www.taylor-company.com

Printed in U.S.A.

055156-ADV 10/07